



INDUSTRIAL VACUUM SYSTEMS

Product group
Mobile Vacuum Units

VacTruck



VacTruck

Powerful vacuum loader for bulk material.
Vacuum cleaning and vacuum conveying in
cement plants, steel plants, power plants and
similar sectors of industry.



wieland lufttechnik
Wetterkreuz 12
91058 Erlangen
Germany
Phone +49 9131 60 67-0
Fax +49 9131 60 44 01
info@wieland-luft.com
www.wieland-luft.com

VacTruck is available in three power versions und with three different collection containers.

VacTruck - basic model

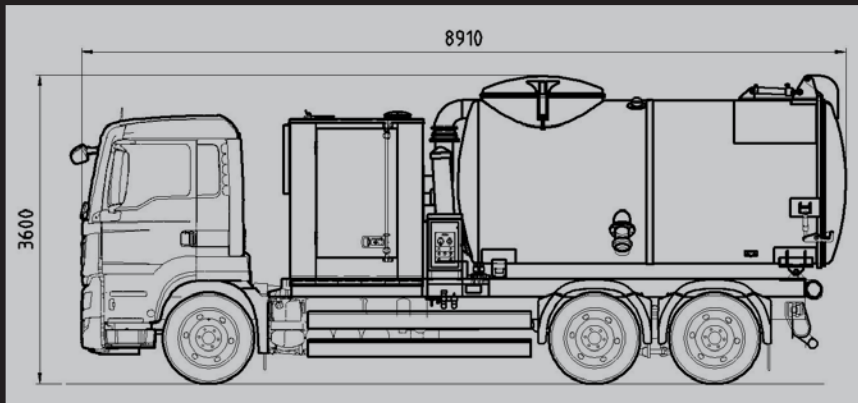

VacTruck - BigBag

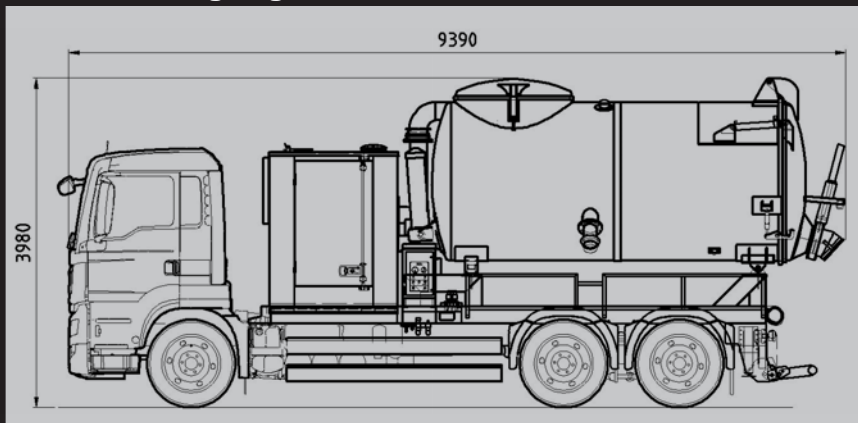

VacTruck - Jumbo

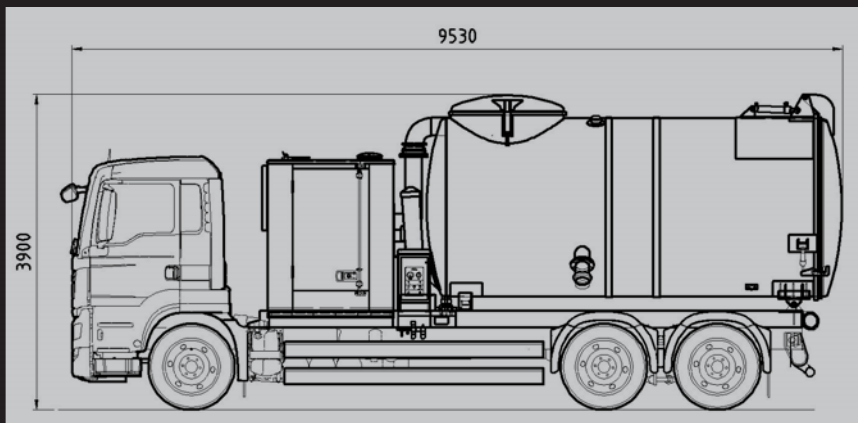

Technical data	Unit	3700-50	6000-50	6000-80
Airflow*	m ³ /h	3700	6000	6000
Suction power*	mbar	550	550	900
Setting vacuum limiter	mbar	500	500	800
Suction inlet	DN		150	
Collection capacity, approx.				
basic model	m ³		9	
BigBag	m ³		9	
Jumbo	m ³		15	
Main filter - Filter surface	m ²	18	24	24
Safety filter	m ²		20	
Noise level (7 m)**	dB(A)		82	

* max. vacuum pump, ** reflexion free

VacTruck - one system, three models

Available as VacTruck 3700-50, 6000-50 and 6000-80. Distinguishes itself by its compact and straight-forward design. VacTruck is designed for three-axle trucks. The extracted suction material is discharged to the rear through its large discharge opening. Robust and safe technology ensure a very high level of availability.

If the suction material needs to be discharged in a dust free way, VacTruck can be equipped with a discharge system for 1000 litre BigBags. The BigBags are filled in a controlled way by means of a discharge slide gate in the discharge door. The required discharge height for this is achieved by a higher mounting position of the collection container. This offers additional storage space below the collection container for suction hoses and accessories. A guard rail makes sure that the load can be securely tied down.

A longer wheel base of the truck allows for a larger collection capacity of 15,000 litres. This model is particularly suitable for light weight suction material. The unit disposes of a tipping discharge system to the rear.

VacTruck - distinctive characteristics

- Compact filter elements with AirShock® filter cleaning device - safe and fast replacement of the main filter.
- Completely electrically grounded as standard equipment. Sources of ignition must not be extracted
- The vacuum pump is driven by the truck engine - no separate Diesel engine required.
- Optional equipment to extract liquid materials.
- Optional equipment to transport liquid materials.

0516-377/1